



## Validation of the Noise Reduction Index (NRI)

Robert Ghent

Michael Nilsson

Victor Bray

### ABSTRACT

Conventional wisdom asserts that a hearing aid cannot fundamentally alter (improve) the input signal-to-noise ratio (SNR) using a single-microphone signal processing algorithm such as digital noise reduction (DNR). The present research explores the validity of the Noise Reduction Index (NRI) by using it to estimate the change in input SNR through a variety of audio devices, including linear hearing aids (with and without directional microphones), a directional microphone designed for noise rejection on a concert stage, an ear trumpet, and a multi-channel hearing aid with a digital noise reduction algorithm both engaged and disengaged. Results indicate that the change in SNR through an audio device can be negative as well as positive, that the NRI is a robust and valid method for estimating this change, and that single-microphone noise reduction algorithms can improve the input SNR when properly designed. The test setup and methodology, along with some pitfalls to avoid when performing these measurements, will be discussed.

## INTRODUCTION

Fundamental to the NRI is a technique described by Licklider, who argued that an engineer needing to separate speech from a background of white noise could do so with two samples of the mixed signal, one with the noise 180° out of phase relative to the noise of the first sample. By adding and subtracting from each other the two wave samples, two new signals would result: noise-free speech and speech-free noise<sup>1</sup>.

Licklider's basic technique was used by Hagerman and Olofsson to evaluate the ability of DNR algorithms in hearing aids to change the input SNR<sup>2</sup>. Their experiment showed that some DNR algorithms improved the SNR.

That a hearing aid could improve the SNR of a mixed signal presented to a single input seems to contradict conventional wisdom and has led some to question the transparency and neutrality of the test method. One way to validate the transparency of the method is to test devices that are designed to not alter the SNR. Conversely, one can test devices that are designed to change the SNR and whose behavior in this regard is known and accepted. Any interaction with the test method will yield unexpected results.

The present study was undertaken to validate the basic technique and explore ways to expand its utility. Some of the expanded utility was a direct outgrowth of the validation process, such as evaluating directional devices, including those with known polar behaviors. Another advantage of the NRI is that measurements are made with the target and masker presented simultaneously. This shows promise in the evaluation of adaptive directional algorithms, for which no adequate testing protocols currently exist.

## METHODS

Two recordings of mixed speech and masking noise are obtained in a sound field, one with the noise 180° out of phase (Figure 1a). The recordings are aligned using clicks at the beginnings of the recorded tracks and the sum/2 and difference/2 of the two recordings is taken, resulting in two new waveforms, one an estimate of the speech energy remaining in the output of DUT and the other the noise energy remaining (Figure 1b). The average rms level of each waveform is obtained over the same time period. The

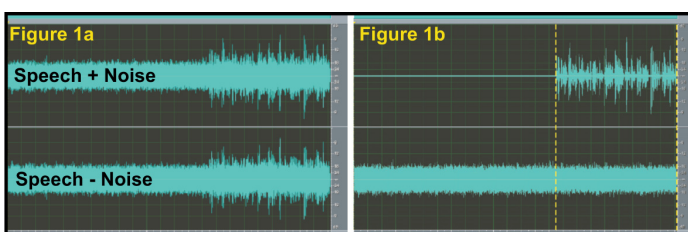

difference between the two measurements is the NRI in dB, where positive numbers indicate an SNR improvement.

Relative to the earlier descriptions of this technique, two factors are unique to the NRI. First, the sound field in which the recordings are made is a two-dimensionally-diffuse (2DD) sound field utilizing four loudspeakers delivering uncorrelated broad-band noise for the masker, with the target speech located at 0° azimuth (Figure 2). Second, the stimuli are derived from the Hearing In Noise Test (HINT)<sup>3</sup>, increasing the clinical relevance of the results and opening an avenue for direct correlation to a widely-used behavioral metric. The description and rationale for this sound field, and its use with the NRI and HINT, have been previously described<sup>4, 5, 6</sup>.

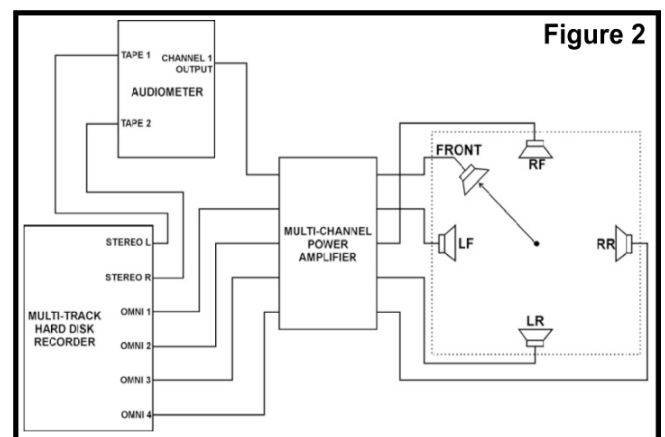

Hearing aid recordings were obtained with a B&K type 4144 measurement microphone (reference condition), connected to a B&K type 2260 Investigator (SLM), with the output fed to a Creative Labs sound card running inside a Dell Dimension computer. Adobe Audition (v. 1.6) was used for recording, editing, and analyzing the audio data, which was sampled at 44.1 kHz with 16-bit resolution. The SLM was used to calibrate the sound field to 65 dBA with equal energy contribution from the four masker loudspeakers, with target speech delivered at 0 dB SNR.

Each measurement in this study was replicated. The test/retest error between the two measurements, averaged across the devices tested, was 0.6 dB. There are two important sources of error to be aware of when making these measurements. First, the sound field speech and noise signals should be calibrated with an A-weighted LEQ in order to maintain the average level equity of the HINT recording. As a result of this calibration, the average rms levels of the recorded samples must be measured, not the total rms levels, otherwise, the results will be overstated. Data reported previously<sup>6</sup> are inflated compared to current data because they were obtained before this source of error was fully understood. Second, alignment of the clicks can be shifted slightly, depending on where the peak occurs relative to the nearest sample (cursor resolution

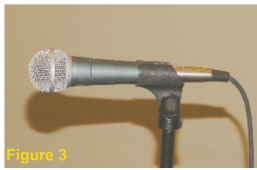

is one sample). Evidence of gross misalignment of the waveforms is incomplete cancellation of noise in the 'speech-only' waveform. Note that this can also occur if the DUT has a high noise floor, which cannot be cancelled.

Devices tested for validation included the measurement microphone, and two passive devices; a stage microphone with a known, supercardioid polar response (Shure Beta 58, Figure 3), and a purely acoustic device (ear trumpet, Figure 4). Additional measurements were made on directional and non-directional BTE hearing aids (Figure 5), with both

analog, broad-band, linear signal processing, and digital, multi-channel compression (MCC) signal processing set for linear operation. All of the hearing aids were set to 15 dB of gain (re: 2 cm<sup>3</sup> coupler). A flat frequency response was used if possible; otherwise the high-frequency average was used, as defined by ANSI7.

Directional microphones were aligned with their port axes parallel to the floor and directed at the target loudspeaker. Testing was accomplished with the primary input of the DUT at the center of the listening position. The ear trumpet was tested with both the subjective and objective ends at the center.

and serves as one facet of the validation effort. The section in orange shows the measurements taken on the passive devices. For validation purposes, these results represent the known or expected behaviors of devices with no additional electronic signal processing. The blue section contains the measurements obtained from the omni-directional, analog hearing aids with linear signal processing, and the yellow section, the directional measurements for devices with similar (or in one case, identical) signal processing. The pink section displays the measurements obtained on a digital hearing aid with MCC signal processing, with directionality and DNR.

The result of 0.0 dB for the reference condition is ideal, indicating that the test environment is neutral and transparent. The stage microphone has an idealized directivity index of 4.7 dB and the NRI obtained here corroborates this expectation within 0.4 dB, indicating that the test method is sensitive to SNR changes exclusive to the DUT. Results for the ear trumpet likewise show expected behavior: moving the objective end closer to the speech source improves SNR by 0.9 dB. NRIs obtained on BTEs 1 - 3 all show a degradation of SNR. Though still degraded, BTE 3 has a directional mode that improves SNR performance by 1.5 dB over the omni-directional mode. Such comparisons demonstrate the NRI's sensitivity to differences in sound processing within the DUT (the electroacoustic signal processing did not change). BTE 4 is a directional-only hearing aid with a 12 mm port spacing and a low-frequency roll-off of 6 dB/octave. This combination of factors yields an excellent NRI at the expense of a natural-sounding frequency response.

The digital hearing aid (BTE 5) has an omni-directional NRI of -0.7 dB with no additional signal processing. Enabling DNR improves the SNR by 1.9 dB, while using a directional microphone alone yields an improvement of 3.1 dB. Using SNR-enhancing features in tandem improves the SNR further as the benefits of the features are layered together. In cases where interactions among layered features may inhibit improved SNR performance, the NRI should, on the basis

## RESULTS & DISCUSSION

Table 1 details the results of the tests for this study. Measurements were rounded to the nearest tenth of a dB. The section highlighted in green indicates the reference condition

of the foregoing, be useful in assessing the impact of such interactions.

DUT	Description	Mean NRI (dB)	Notes
Ref. Microphone	1" measurement microphone	0.0	Polarizing pre-amplifier required.
Stage Microphone	Dynamic, supercardioid	4.3	No external pre-amplification.
Ear Trumpet	Hard rubber construction	-0.8	Subjective end at center.
Ear Trumpet		0.1	Objective end at center.
BTE 1	Analog, Linear, Omni	-5.6	1970s vintage
BTE 2	Analog, Linear, Omni	-3.3	1980s vintage
BTE 3	Analog, Linear, Omni	-5.8	1990s vintage
BTE 3	Analog, Linear, Dir	-4.3	Unequalized directional response.
BTE 4	Analog, Linear, Dir	6.4	Unequalized directional response.
BTE 5	Digital, MCC, Omni, NR Off	-0.7	MCC = 16 independent channels.
BTE 5	Digital, MCC, Omni, NR On	1.2	NR set at Maximum.
BTE 5	Digital, MCC, Dir, NR Off	2.4	Fixed hypercardioid polar response.
BTE 5	Digital, MCC, Dir, NR On	4.8	
BTE 5	Digital, MCC, Dir, DF On, NR Off	2.9	DF = Beam forming algorithm.
BTE 5	Digital, MCC, Dir, DF On, NR On	5.9	All SNR signal processing engaged.

## CONCLUSIONS

---

The NRI has been shown to be neutral and transparent, reflecting only the changes to the input SNR imposed by the DUT. It has also been shown to be sensitive to differences in sound processing features that can change the SNR at the level of the DUT, including directional microphones. Given that the NRI exhibits such transparent sensitivity to the known or expected SNR impact of directional microphones, the test method is similarly transparent and sensitive to the operation of other features, such as DNR algorithms, as demonstrated in this study. The NRI does not provide information as to how the device changes the SNR, only that it has changed.

## REFERENCES

---

1. Licklider, JCR. (1948). The influence of interaural phase relations upon the masking of speech by white noise. *J. Acoust. Soc. Am.*, 20, 150-159.
2. Hagerman, B. and Olofssen, A. (2004). A method to measure the effect of noise reduction algorithms using simultaneous speech and noise. *Acta Acoust.*, 90, 356-361.
3. Nilsson, M., Soli, S., & Sullivan, J. (1994). Development of the Hearing In Noise Test for the measurement of speech reception thresholds in quiet and in noise. *J. Acoust. Soc. Am.*, 95, 1085-1099.
4. Ghent, R. (2005). A tutorial on complex sound fields for audiometric testing. *J. Am. Acad. Audiol.*, 16, 18-26.
5. Nilsson, M., Ghent, R., Bray, V., & Harris, R. (2005). Development of a test environment to evaluate performance of modern hearing aid features. *J. Am. Acad. Audiol.* 16, 27-41.
6. Nilsson, M. & Bray, V. (2004). The Noise Reduction Index: Benchtop estimate of SNR changes. Poster presented at the International Hearing Aid Research Conference, Tahoe City, CA.
7. American National Standards Institute. (1996). S3.22: Specification of hearing aid characteristics. New York, ANSI.

